

**E1.2 Digital Electronics 1  
Solutions 2008**

All questions are unseen.

**Answer to Question 1 (Compulsory)**

a) i)

$$\begin{aligned}
 & ABC + \bar{A}CD + \bar{B}CD \\
 &= C(AB + \bar{A}D + \bar{B}D) \\
 &= C(AB + D(\bar{A} + \bar{B})) \\
 &= C(AB + \overline{ABD}) \\
 &= C(AB + D) \\
 &= ABC + CD
 \end{aligned}$$

[4]

ii)

$$\begin{aligned}
 & AB + (C + \bar{B})(AB + \bar{C}) \\
 &= AB + C(AB + \bar{C}) + \bar{B}(AB + \bar{C}) \\
 &= AB + ABC + \bar{B}\bar{C} \\
 &= AB(1 + C) + \bar{B}\bar{C} \\
 &= AB + \bar{B}\bar{C}
 \end{aligned}$$

[4]

b)

		YZ			
		00	01	11	10
X	0	0	1	1	0
	1	1	1	0	1

$$\begin{aligned}
 & F(X, Y, Z) \\
 &= \bar{X}Z + X\bar{Z} + X\bar{Y} \quad \text{or} \\
 &= \bar{X}Z + X\bar{Z} + \bar{Y}Z
 \end{aligned}$$

[4]

c)

		CD			
		00	01	11	10
AB	00	1	1	0	1
	01	0	1	0	0
	11	0	0	0	0
	10	1	1	0	1

$$F = (\bar{A} + \bar{B})(\bar{C} + \bar{D})(\bar{B} + D)$$

[4]

d)

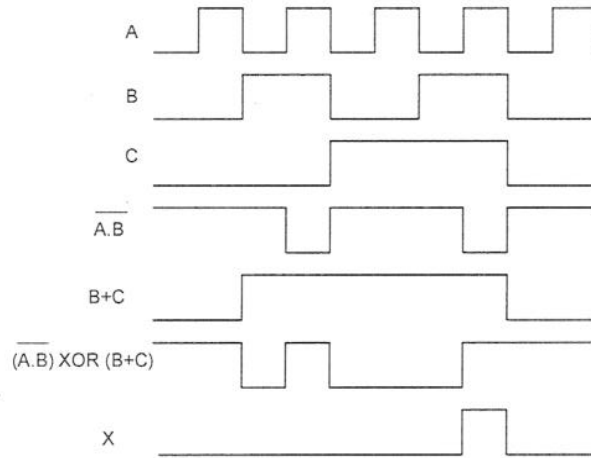

[4]

e)

Binary	Hexadecimal	Unsigned Decimal	Signed Decimal	ASCII
<b>0100 0110</b>		70		<b>'F'</b>
	D4	<b>212</b>	<b>-44</b>	

2 marks each.

[8]

- f) P is reset input (high active), and Q is set input to the flip-flop (R=1 is set state). The two AND gates and the inverter forms a steering circuit, steering the clock pulse on B depending on value of A. When A is high, the clock pulse is steered to reset input and when A is low, the clock pulse is steered to the set input. Hence the waveforms are:

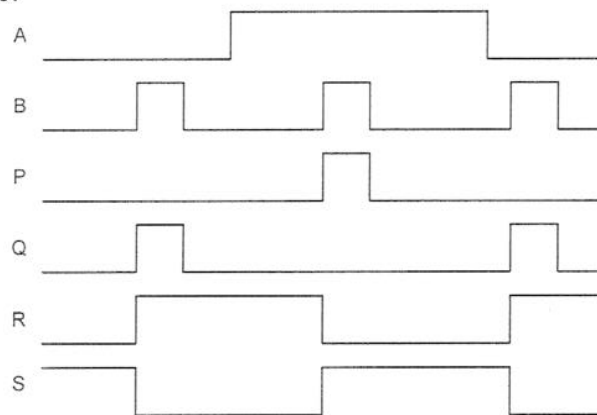

[6]

g)

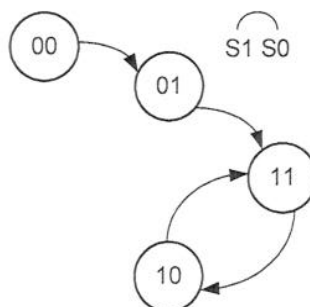

[6]

**Answer to Question 2**

a)

	PQ			
B <sub>in</sub>	00	01	11	10
0	0	1	0	1
1	1	0	1	0

D

	PQ			
B <sub>in</sub>	00	01	11	10
0	0	1	0	0
1	1	1	1	0

B<sub>out</sub>

$$D = \overline{P}\overline{Q}B_{in} + P\overline{Q}\overline{B}_{in} + \overline{P}Q\overline{B}_{in} + PQB_{in} \quad B_{out} = \overline{P}Q + B_{in}Q + B_{in}\overline{P}$$

[8]

b) Need to express both equations as NOR or inverter functions only:

$$\begin{aligned} D &= \overline{P}\overline{Q}B_{in} + P\overline{Q}\overline{B}_{in} + \overline{P}Q\overline{B}_{in} + PQB_{in} \\ &= \overline{\overline{\overline{P}\overline{Q}B_{in}} + \overline{\overline{P\overline{Q}\overline{B}_{in}} + \overline{\overline{\overline{P}Q\overline{B}_{in}} + \overline{\overline{PQB_{in}}}}} \\ &= \overline{\overline{\overline{P}\overline{Q}B_{in}} + \overline{\overline{P\overline{Q}\overline{B}_{in}} + \overline{\overline{\overline{P}Q\overline{B}_{in}} + \overline{\overline{PQB_{in}}}}} \\ &= \overline{(P + Q + \overline{B}_{in}) + (\overline{P} + Q + B_{in}) + (P + \overline{Q} + B_{in}) + (\overline{P} + \overline{Q} + \overline{B}_{in})} \end{aligned}$$

[4]

$$\begin{aligned} B_{out} &= \overline{P}Q + B_{in}Q + B_{in}\overline{P} \\ &= \overline{\overline{\overline{\overline{P}Q} + \overline{\overline{B_{in}Q} + \overline{\overline{B_{in}\overline{P}}}}} \\ &= \overline{\overline{\overline{P}Q} + \overline{\overline{B_{in}Q} + \overline{\overline{B_{in}\overline{P}}}}} \\ &= \overline{(P + \overline{Q}) + (\overline{B}_{in} + \overline{Q}) + (\overline{B}_{in} + P)} \end{aligned}$$

[4]

c)

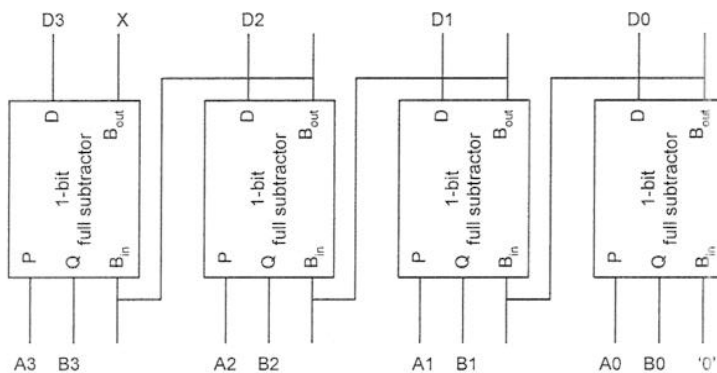

$$X = \text{Borrow\_out from MSB} = (B > A)$$

[8]

d)

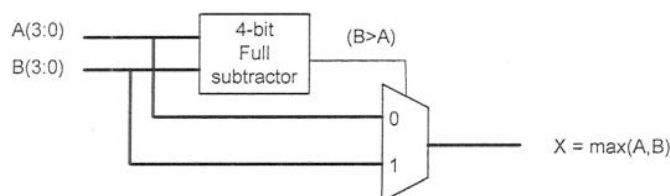

[6]

### Answer to Question 3

a)

$$\begin{aligned}
 Z &= (D\bar{C} + 1 \cdot C)\bar{B} + (D\bar{A} + 1 \cdot A)B \\
 &= (D + C)\bar{B} + (D + A)B \\
 &= \bar{B}D + \bar{B}C + BD + AB \\
 &= AB + BC + D
 \end{aligned}$$

[10]

b) Need to express the Boolean equation in the form:  $Z = F_1\bar{D} + F_2D$

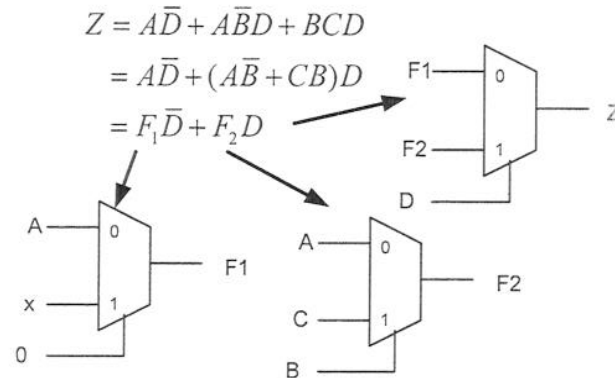

Hence to implement the required equation, we want:

$$A_0 = B_0 = A, A_1 = 'x', S_A = '0', B_1 = C, S_B = B, S = D$$

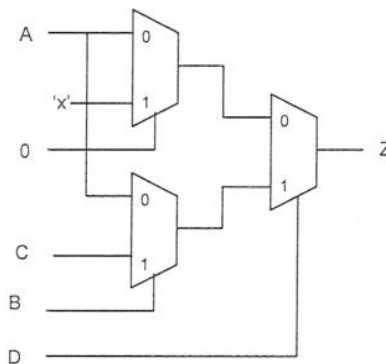

[10]

c) This is a positive edge trigger D flip-flop, with asynchronous clear. Data input = W, clock input is X, clear control is Y.

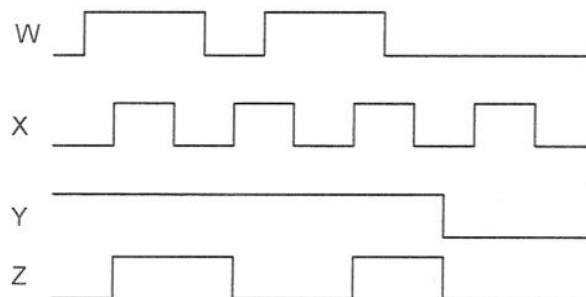

[10]

Answer to Question 4

a)

A	B	X	NextA	NextB	Y
0	0	0	0	0	0
0	0	1	0	1	1
0	1	0	1	0	0
0	1	1	0	1	0
1	0	0	1	0	0
1	0	1	1	1	1
1	1	0	1	1	0
1	1	1	0	0	0

[6]

b)

		AB			
NextA		00	01	11	10
X	0	0	1	1	1
	1	0	0	0	1

$$\text{NextA} = \overline{B}X + A\overline{B}$$

		AB			
NextB		00	01	11	10
X	0	0	0	1	0
	1	1	1	0	1

$$\text{NextB} = \overline{A}X + \overline{B}X + AB\overline{X}$$

		AB			
Y		00	01	11	10
X	0	0	0	0	0
	1	1	0	0	1

$$Y = \overline{B}X$$

[14]

c)

This new encoding (known as one-hot encoding) allows very simple implementation of next state equations and outputs. By inspection:

$$\begin{aligned} \text{NextS1} &= S0 X \\ \text{NextS2} &= S1 \overline{X} \\ \text{NextS3} &= S2 X \\ \text{Next S0} &= S3 X \end{aligned}$$

$$Y = S0 X + S2 X$$

[10]