

Special information for invigilators: Q1 is Compulsory

Information for candidates

charge: $e = 1.6 \times 10^{-19} \text{ C}$
 permittivity of free space : $\epsilon_0 = 8.85 \times 10^{-12} \text{ F/m}$
 permeability of free space : $\mu_0 = 4\pi \times 10^{-7} \text{ H/m}$

Formulae

$$J_n(x) = e\mu_n n(x)E(x) + eD_n \frac{dn(x)}{dx}$$

$$J_p(x) = e\mu_p p(x)E(x) - eD_p \frac{dp(x)}{dx}$$

$$J_{tot} = J_n + J_p$$

$$I_{DS} = \frac{\mu C_{ox} W}{L} \left((V_{GS} - V_T) V_{DS} - \frac{V_{DS}^2}{2} \right)$$

$$f_t = \frac{g_m}{2\pi C}$$

$$J_n = \frac{eD_n n_p}{L_n} \left(e^{\frac{eV}{kT}} - 1 \right)$$

$$J_p = \frac{eD_p p_n}{L_p} \left(e^{\frac{eV}{kT}} - 1 \right)$$

$$\int \sin^2 x dx = \frac{1}{2}x - \frac{1}{4}\sin(2x)$$

Drift and diffusion currents in a semiconductor

Drift current in a MOSFET

Cut-off frequency of a MOSFET

Diffusion currents in a pn-junction when both defined in the +x direction.

Compulsory

- a) Why does the mobility of free carriers reduce when the doping density in the semiconductor increases? [4]
- b) Give the relationship (<, > or =) between the density of the free minority carriers in material 1 and material 2 with energy band diagrams given in Figure 1. [4]

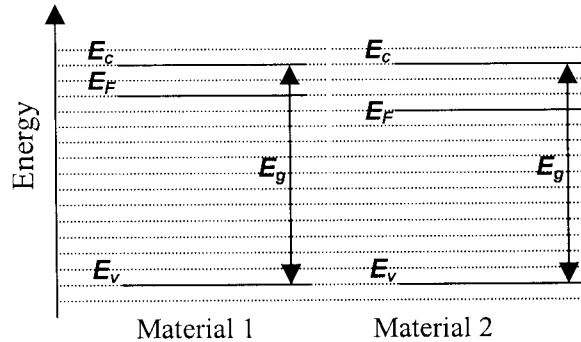

Figure 1: The energy band diagrams of two materials.

- c) Which carrier type accumulates at the interface between metal and n-type semiconductor of an un-biased ohmic contact? [4]
- d) Name the four types of carrier flux that occur across a pn junction when no external bias is applied. [4]
- e) Does an n-channel depletion mode MOSFET conduct when $V_{GS} = 0$? Explain briefly the reasons for your answer. [4]
- f) Derive an expression for the saturation current in an n-type MOSFET at pinch-off (onset of saturation) as a function of gate voltage. [4]
- g) The collector current in a bipolar transistor, in active mode, can be deduced from carrier concentration variations. In which region of the bipolar transistor is the collector current calculated? [4]
- h) A 100 nF capacitor holds a charge of $2 \mu\text{C}$. Find the work needed, in Joules, to move an electron from the positive to the negative plate of the capacitor. [4]
- i) An ideal transformer has 20 and 10 turns on the input and output sides respectively. If a 50Ω resistor is connected to the output terminals, find the referred load as measured at the input terminals. [4]
- j) Calculate the magnetic flux density B at a point 3 cm from a long straight wire carrying a current of 20 A. [4]

2.

- a) Give a definition of the threshold voltage for an n-channel MOSFET in terms of carrier concentrations. [4]
- b) Describe two methods for changing the value of the threshold voltage of an n-channel MOSFET. [4]
- c) Sketch the energy band diagram (E_c , E_v , E_g , E_F) perpendicular to the gate (x direction in figure 2.1) through all layers of the MOS-capacitor on a p-type Si substrate when no external bias is applied. The workfunction of the metal ϕ_m is larger than the workfunction of the semiconductor ϕ_s , i.e. $\phi_m > \phi_s$. [8]

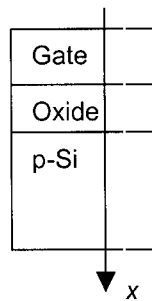

Figure 2.1: The MOS-capacitor with the definition of the direction perpendicular to the gate

- d) Give the complete small signal equivalent circuit of a MOSFET, including all capacitors and contact resistances. Define all the elements in the equivalent circuit. [6]
- e) Consider an ideal n-channel MOSFET with a gate width-to-length ratio of 10, gate length of 1 μm , an electron mobility of 400 cm^2/Vs , a hole mobility of 200 cm^2/Vs , an oxide thickness of 10 nm, and a threshold voltage of $V_T = 0.5 \text{ V}$. Calculate the cut-off frequency at $V_{GS} = 1.5 \text{ V}$ and $V_{DS} = 2 \text{ V}$. Ignore the influence of the contact resistances. [8]

3.

- a) A steady state flow of electrons is injected into one face, at $x = 0$, of a p-type semiconductor slab as illustrated in Figure 3.1. Sketch the excess electron density variation in the semiconductor as a function of x when:
- The length of the semiconductor is longer than the electron diffusion length.
 - The length of the semiconductor is shorter than the electron diffusion length.
- Annotate your sketches with the necessary parameters. [7]

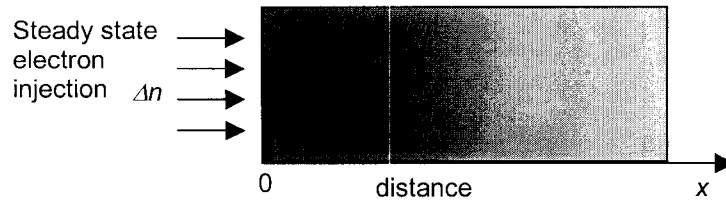

Figure 3.1: p-type semiconductor with steady state electron injection at $x = 0$ with Δn the excess electron concentration injected.

- b) Sketch, on a single graph, the variation of the excess minority carrier concentration in the n-side of a pn-junction, as a function of distance from the junction towards the contact at 3 or 4 successive instances in time, in the case when:
- The diode is switched from forward bias to zero bias
 - The diode is switched from forward bias to reverse bias.
- Ensure that all carrier gradients are consistent and indicate the time sequence. [8]
- c) For an npn BJT with a narrow base, derive the relationship between the current gain β and the emitter efficiency γ . The emitter efficiency is the ratio of the current injected from E to B to the total E-B junction current. You can neglect the reverse bias leakage across the B-C junction. Make sure you explain each step in your derivation. [7]
- d) Calculate the ratio of the emitter doping to the base doping of the npn BJT of question 3c), in order to achieve an emitter injection efficiency $\gamma = 0.996$. To do this you will have to write the emitter efficiency as a function of material parameters. The diffusion constant of the electrons is twice the hole diffusion constant. The diffusion lengths of electrons and holes are the same. [8]

4. a) A certain parallel plate capacitor has square plates of area $w \times w$, with $w = 1 \text{ mm}$, separated by a gap of length $d = 10 \text{ }\mu\text{m}$ which is filled with a dielectric sheet of relative permittivity $\epsilon_r = 3$. The capacitor is charged to 10 V , and the external circuit is then disconnected. Calculate the stored charge Q , and the magnitude of the electric field E within the dielectric. Indicate any approximations or assumptions you have made. [4]
- b) Assuming the charge Q remains constant and the plate separation is not altered, calculate the work W that would be needed to remove the dielectric sheet completely from between the plates, and the force F on the dielectric pulling it back into the gap when it is partially removed. [6]
- c) Sketch in your answer book a cross-section of the capacitor like that of Figure 4.1, and add to your sketch electric field lines. Your lines should have arrows indicating the direction of the field. On a second sketch of the cross-section, draw equipotential lines. About 10 field and 4 equipotential lines are suggested. [5]
- d) A hollow conducting sphere is now added to the centre of the capacitor, as in Figure 4.2. Assuming the net charge of the sphere is zero, draw two sketches of the cross-section, with electric field lines and equipotential lines added respectively. The number of field and equipotential lines should be chosen to illustrate the main features without excessive crowding. [5]

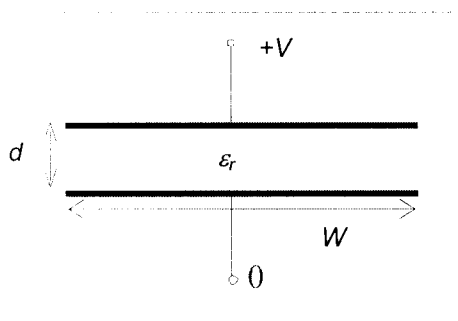

Figure 4.1

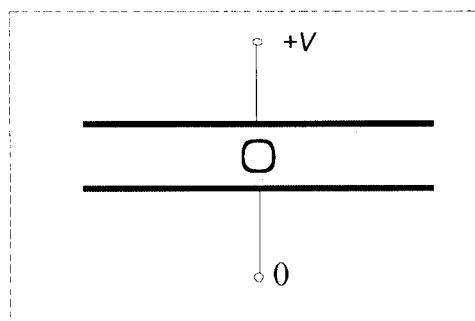

Figure 4.2

5. a) A rectangular coil of N turns, having dimensions $w \times h$, moves into a magnetic field at a constant velocity v , as illustrated in Figure 5.1. The flux density is uniform with a value B up to a boundary, beyond which it is zero, and is perpendicular to the plane of the coil. The terminals of the coil are open circuit as shown. The distance $s(t)$ indicates the distance to which the coil has extended into the field region. For $N = 20$, $w = 5$ cm and $h = 8$ cm, $B = 2$ T, $v = 2$ m/s, and $0 < s < 5$ cm, calculate the voltage generated across the output terminals. [8]
- b) A $10 \text{ k}\Omega$ resistor is now connected across the output terminals of the coil. Calculate the electrical power generated in the coil, for the same coil velocity of 2 m/s. [8]
- c) Calculate, from the result of (b), the total work done to insert the coil, i.e. from $s = 0$ to $s = w$. [7]
- d) For arbitrary dimensions h and w and flux density B , with an arbitrary resistance R connected to the terminals, derive an expression for the work required to rotate the coil through 90° about its x -axis (shown as dotted line) at a uniform speed of rotation ω . Assume that the coil is entirely within the field (i.e. $s = w$). [7]

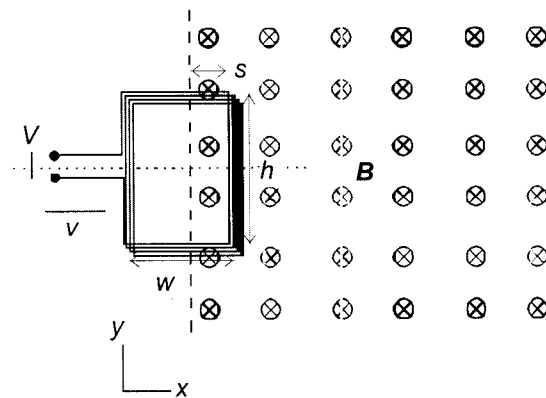

Figure 5.1

1 This question is compulsory

- a) The introduction of more doping atoms (impurities) will increase the scattering events and this decreases the mean free time between scattering events (collisions) τ . The mobility is proportional to τ . [4]
- b) The minority carriers are holes. $\rho_{Mat1} < \rho_{Mat2}$ [4]
- c) Electrons (majority carrier) [4]
- d) Hole drift flux, hole diffusion flux, electron drift flux and electron diffusion flux
- e) Yes, since without gate bias there is already a channel available for conduction [4]
- f)
$$I_{DS} = \frac{\mu C_{ox} W}{L} \left((V_{GS} - V_T) V_{DS} - \frac{V_{DS}^2}{2} \right)$$
 [3]

$$V_{DS} = (V_{GS} - V_T) \text{ at pinch-off}$$
 [4]

$$I_{DS}^{sat} = \frac{\mu C_{ox} W}{2L} (V_{GS} - V_T)^2$$
- g) The base (minority carrier concentration variation in the base) [4]
- h) $V = Q/C = 2 \times 10^{-6} / 100 \times 10^{-9} = 20V$. [4]
 $W = QV = 20V \times 1.6 \times 10^{-19} C = 3.2 \times 10^{-18} J$.
- i) $Z_L' = (N_1/N_2)^2 Z_L = 4 \times 50 \Omega = 200 \Omega$. [4]
- j) By Ampere's law, $2\pi rH = I$, so $H = I/(2\pi r)$, $B = \mu_0 H = \mu_0 I/(2\pi r)$
 $B = 4\pi \times 10^{-7} \times 20 / (2\pi \times 0.03) = 0.13 \text{ mT}$ [4]

2

- a) The threshold voltage is the gate voltage that needs to be applied in order to make the magnitude of the carrier density in the inversion the same as the carrier density in the bulk far away from the Si/SiO₂ interface. [4]
- b) Change the oxide thickness
Change the doping in the bulk (substrate) [4]
- c) [8]

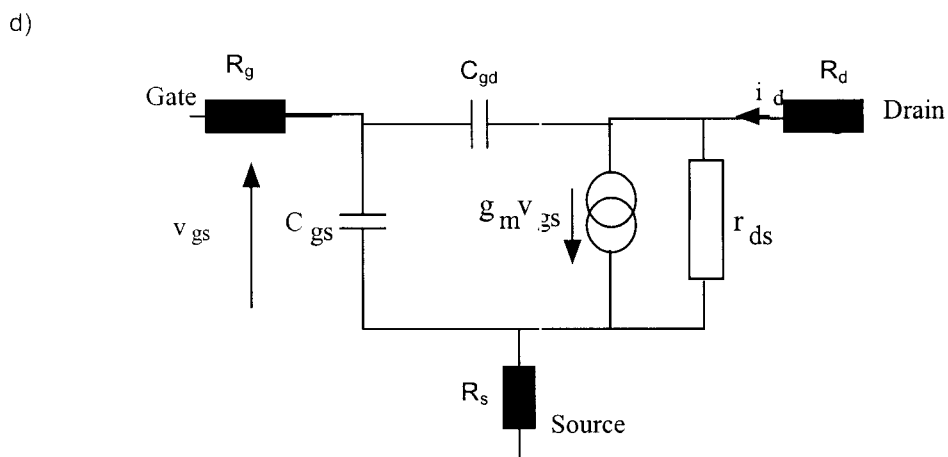
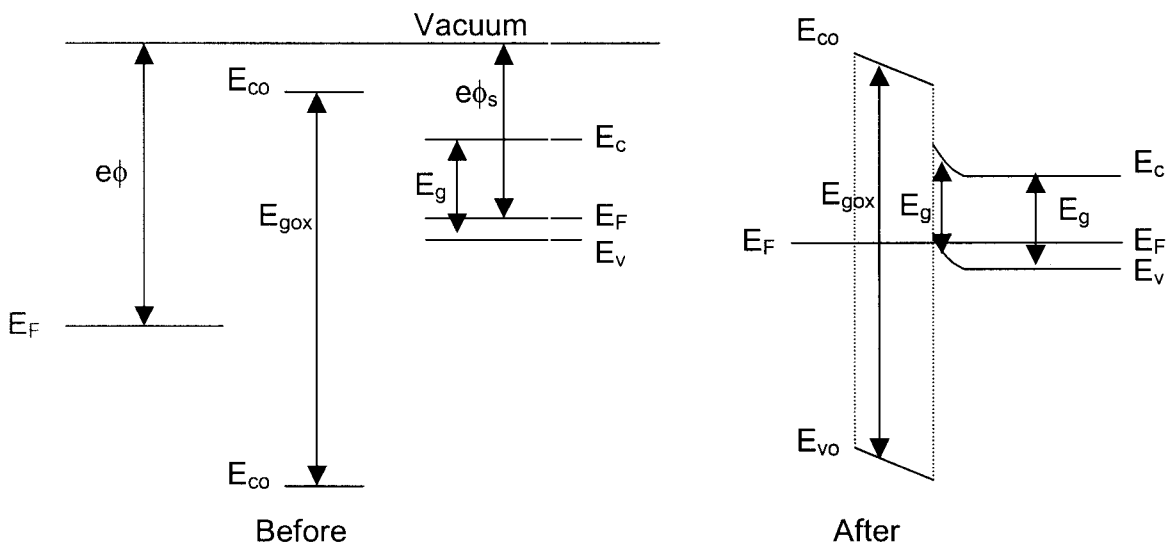

Transconductance, g_m
 $g_m = dI_D / dV_{GS}$ at constant V_{DS}
 Output Resistance
 $r_{ds} = 1 / g_{ds} = (dI_D / dV_{DS})^{-1}$ at constant V_{GS}
 Input (Gate-Source) Capacitance, C_{gs}
 $C_{gs} = dQ_{gs} / dV_{gs}$
 Drain-Gate Capacitance, C_{gd}
 $C_{gd} = dQ_{gd} / dV_{gd}$

[E1.3]

[6]

e)

[8]

$V_{DS} > V_{GS} - V_T \rightarrow \text{saturation}$

$$f_T = \frac{g_m}{2\pi C_{GS}} \text{ as } C_{gd}^{sat} = 0$$

$$I_{DS}^{sat} = \frac{\mu C_{ox} W}{2L} (V_{GS} - V_T)^2$$

$$g_m^{sat} = \frac{dI_{DS}^{sat}}{dV_{GS}} = \frac{\mu C_{ox} W}{L} (V_{GS} - V_T)$$

$$C_{gs}^{sat} = \frac{2}{3} C_{ox} W \cdot L$$

$$f_T = \frac{\frac{\mu C_{ox} W}{L} (V_{GS} - V_T)}{2\pi \frac{2}{3} C_{ox} W \cdot L} = \frac{3\mu(V_{GS} - V_T)}{4\pi L^2} = \frac{3 \cdot 400 \text{ V}}{4 \cdot \pi (10^{-4})^2} \approx 95.5 \cdot 10^8 \text{ Hz}$$

3.

a)

- i) The length of the semiconductor is longer than the electron diffusion length: exponential variation.

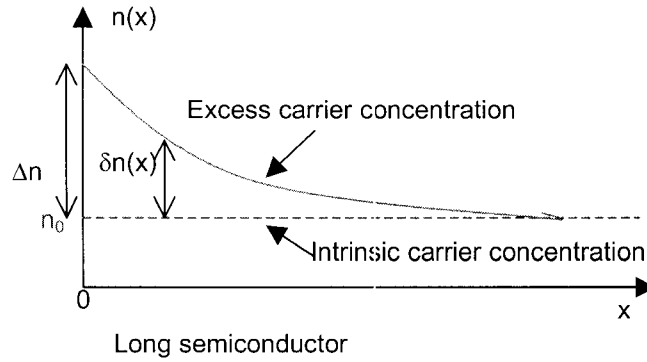

- ii) The length of the semiconductor L is shorter than the electron diffusion length, linear variation.

[7]

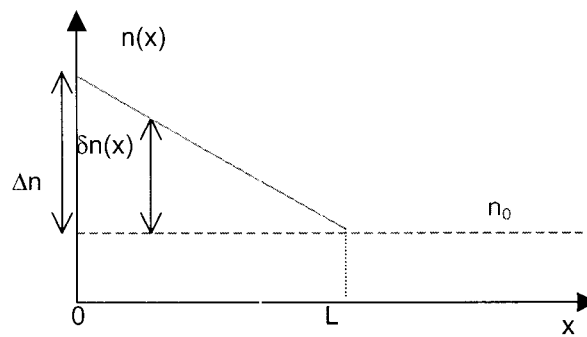

b)

- i) The diode is switched from forward bias to zero bias

[8]

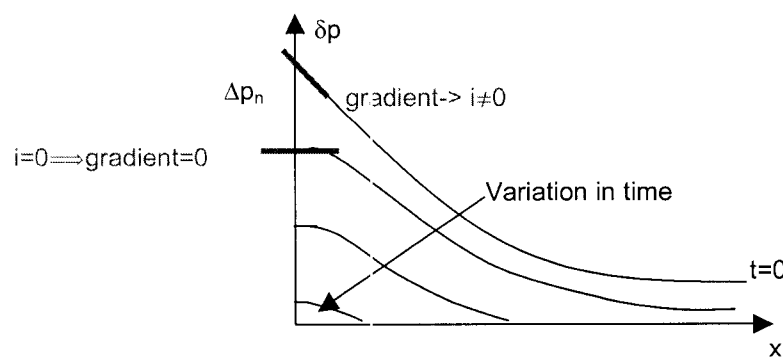

ii) The diode is switched from forward bias to reverse bias.

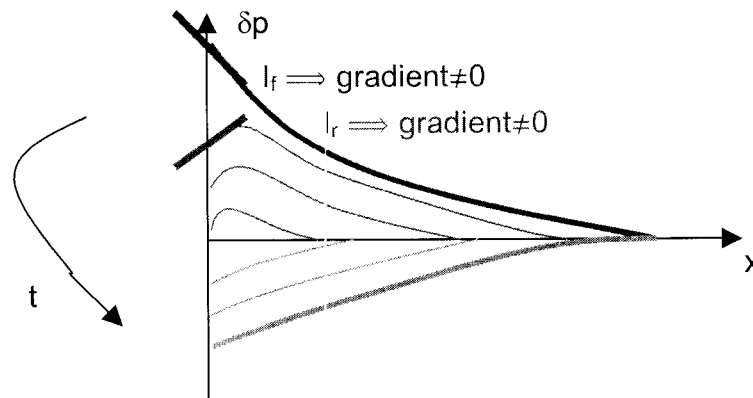

c) Definitions of current gain and emitter injection efficiency:

$$\beta = \frac{I_C}{I_B}$$

$$\gamma = \frac{I_{En}}{I_{En} + I_{Ep}} = \frac{1}{1 + I_{Ep}/I_{En}} \quad \text{where } I_{En} \text{ and } I_{Ep} \text{ are resp. the electron current injected}$$

from emitter into base and hole current injected from base into emitter. Since the base is short, no recombination happens in the base, and I_{CBO} can be ignored, this means that the collector current is equal to the electron current injected by the emitter: $I_C = I_{En}$ and that the base current is simply the hole injection from the base into the emitter: $I_B = I_{Ep}$. Substitution of these equations into the expression

$$\text{for } \gamma \text{ gives: } \gamma = \frac{1}{1 + I_B/I_C} = \frac{1}{1 + 1/\beta} \quad [7]$$

d) From c), we have $\gamma = \frac{1}{1 + I_{Ep}/I_{En}}$. Using the expression for the diode currents for

electron and holes given in the formulae sheet we can derive γ as a function of the material parameters:

$$\gamma = \frac{1}{1 + I_{Ep}/I_{En}} = \frac{1}{1 + \frac{eD_p p_n \left(e^{eV/kT} - 1 \right)}{L_p} \bigg/ \frac{eD_n n_p \left(e^{eV/kT} - 1 \right)}{L_n}} = \frac{1}{1 + \frac{D_p L_n p_n}{D_n L_p n_p}}$$

$$p_n = \frac{n_i^2}{N_D} \quad \& \quad n_p = \frac{n_i^2}{N_A} \rightarrow$$

$$\gamma = \frac{1}{1 + \frac{D_p L_n N_A}{D_n L_p N_D}} \quad [8]$$

$$D_n = 2D_p \quad \& \quad L_n = L_p \rightarrow$$

$$\gamma = \frac{1}{1 + \frac{N_A}{2N_D}} \rightarrow \frac{N_D}{N_A} = \frac{\gamma}{2(1-\gamma)} = \frac{0.996}{0.008} = 124.5$$

4. a) $C = \frac{\epsilon_r \epsilon_0 A}{d}$
 $= \frac{3 \times 8.85 \times 10^{-12} \text{ F/m} \times (10^{-3} \text{ m})^2}{10^{-5} \text{ m}}$
 $= 2.66 \text{ pF}$. $Q = CV = 2.66 \text{ pF} \times 10 \approx 27 \text{ pC}$
 approximation: fringing fields neglected

b) The work can be calculated by integrating the force, but better to compare stored energy before and after. Note this is a constant charge case, the voltage changes!

$$W = U_2 - U_1 = \frac{1}{2} C_2 V_2^2 - \frac{1}{2} C_1 V_1^2$$

$$C_2 V_2 = C_1 V_1 \therefore W = \frac{1}{2} C_1 V_1^2 \left(\frac{C_2}{C_1} - 1 \right)$$

$$= \frac{1}{2} (2.66 \text{ pF}) (10)^2 (\epsilon_r - 1) \quad \epsilon_r = 3$$

$$W = 266 \text{ pJ}$$

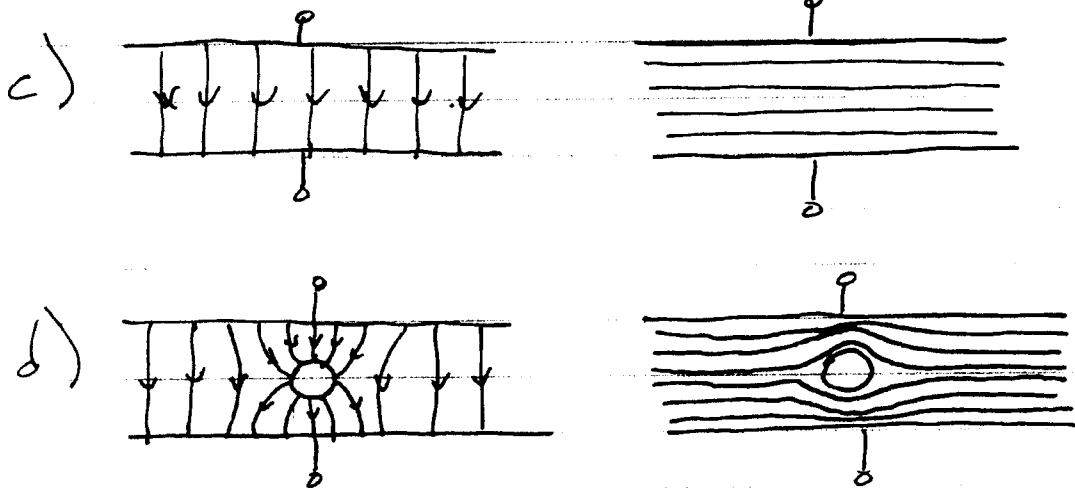

$$5. a) V = N \frac{d\Phi}{dt}$$

$$\Phi = BA = Bsh \quad (\text{since } B \perp \text{coil})$$

$$\frac{d\Phi}{dt} = Bh \frac{ds}{dt} = Bhv$$

$$= 2 \times 0.08 \times 2 = 0.32 \text{ V}$$

$$V = N \frac{d\Phi}{dt} = 20 \times 0.32 = 6.4 \text{ V}$$

$$b) P = \frac{V^2}{R} = \frac{6.4^2}{10^4} = 4.1 \text{ mW (DC)}$$

$$c) W = \int P dt = \frac{V^2}{R} \Delta t = \frac{V^2}{R} \frac{W}{v}$$

$$= \frac{N^2 h^2 v^2 B^2 W}{Rv} = (NhB)^2 vW / R$$

$$= (20 \times 0.08 \times 2)^2 \times 2 \times 0.05 / 10^4 = 0.10 \text{ mJ}$$

d)

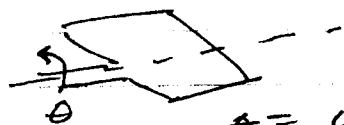

$$\Phi = (wh \cos \theta) B \quad V = NwhB \left(\frac{d(\cos \theta)}{dt} \right) = Nwh \omega \sin \theta$$

$$P = V^2 / R = (Nwh \omega)^2 \sin^2 \theta / R \quad d\theta = \omega dt$$

$$W = \int_0^T P dt = \frac{(NwhB)^2 \omega}{R} \int_0^{\omega T} \sin^2 \theta d\theta$$

$$T = \text{time to turn } 90^\circ = \frac{1}{\omega} \left(\frac{2\pi}{4} \right) = \frac{\pi}{2\omega} \quad \omega T = \pi/2$$

$$\int_0^{\pi/2} \sin^2 \theta d\theta = \left[\frac{1}{2} \theta - \frac{1}{4} \sin 2\theta \right]_0^{\pi/2} = \frac{\pi}{4}$$

$$W = \frac{(NwhB)^2 \omega \pi}{4}$$